

ΠΙΝΑΚΑΣ ΥΔΡΑΥΛΙΚΟΣ ΕΚΚΙΝΗΣΗΣ ΑΠ' ΕΥΘΕΙΑΣ & ΑΣΤΕΡΑ-ΤΡΙΓΩΝΟ +A3
 [PANEL HYDRAULIC DIRECT & STAR-DELTA START +A3]
 V3.1_3.2 R170323
 File: D.ZM.H.DI-SD.A3 V3.1_3.2 R170323 [Hyd Dir and Star-Delta Start +A3 SS_Pz]
 ZERO MAX (LF2050-5B, 2061, V1.83/1.85)

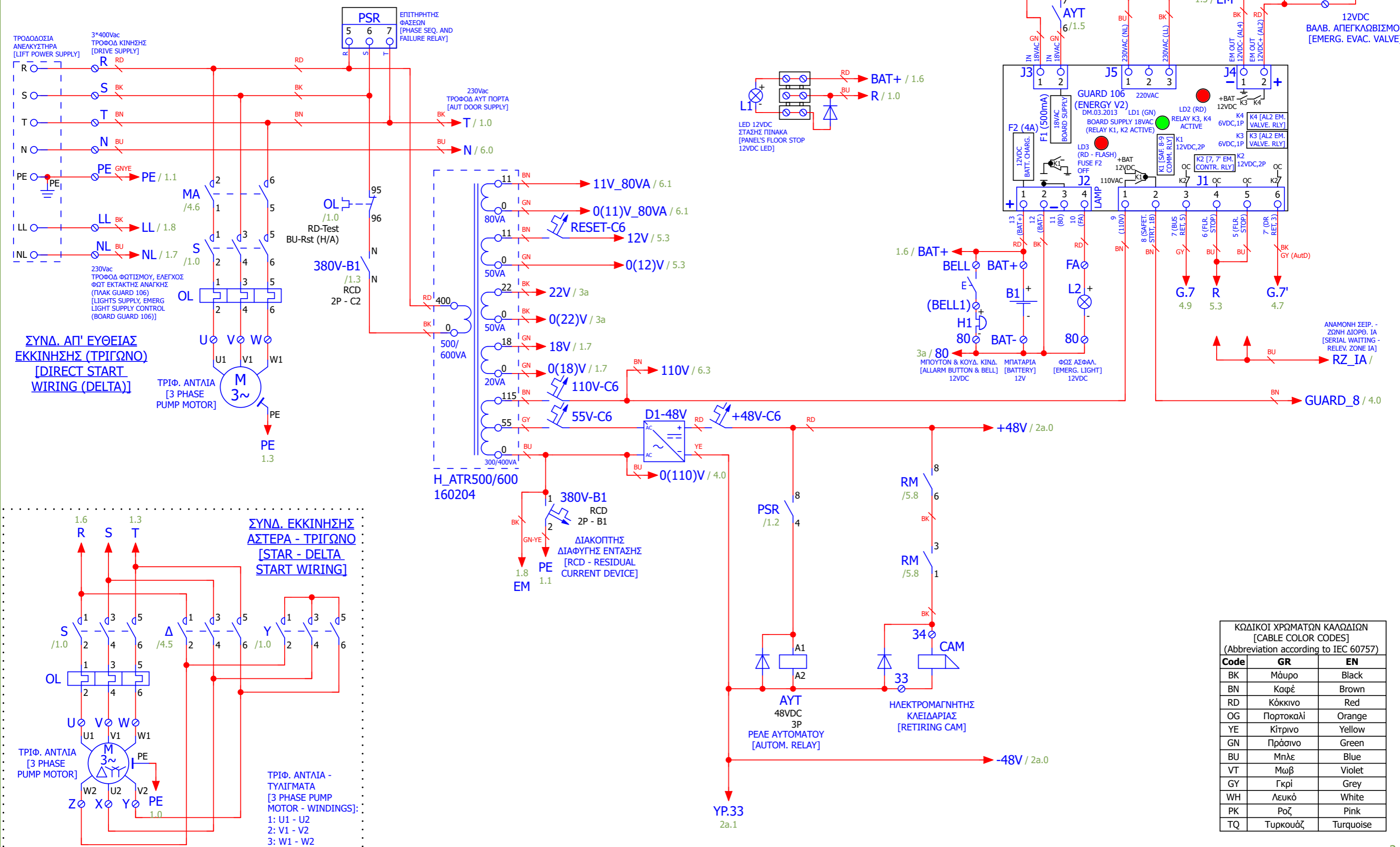

Code: D.ZM.H.DI-SD.A3
 Spec:
 Vers./Rel.: V3.1 3.2 R170323
 Board/Mem: Zero Max V1.83 / V1.85

StamTec - Elevator Control Panels
 Head Office: Ind. Zone of Sindos, OT 43, DA 11, P.C. 57022
 Thessaloniki, GREECE, Tel/Fax: +30 2310-459902, 795880, 795691
 Email: info@stamtec.gr, Website: www.stamtec.gr



DWG: Zero Max Panel - Hydraulic Direct & Star-Delta Start (V3.1 & V3.2)

= H
 + V3.1_3.2
 Page: 1
 Tot. Nr. Pages: 10

ΜΟΝΑΔΑ ΙΣΧΥΟΣ ΜΕ ΒΑΛΒΙΔΕΣ BLAIN EV100 + L10 (A3)
 [POWER UNIT WITH BLAIN VALVES EV100 + L10 (A3)]

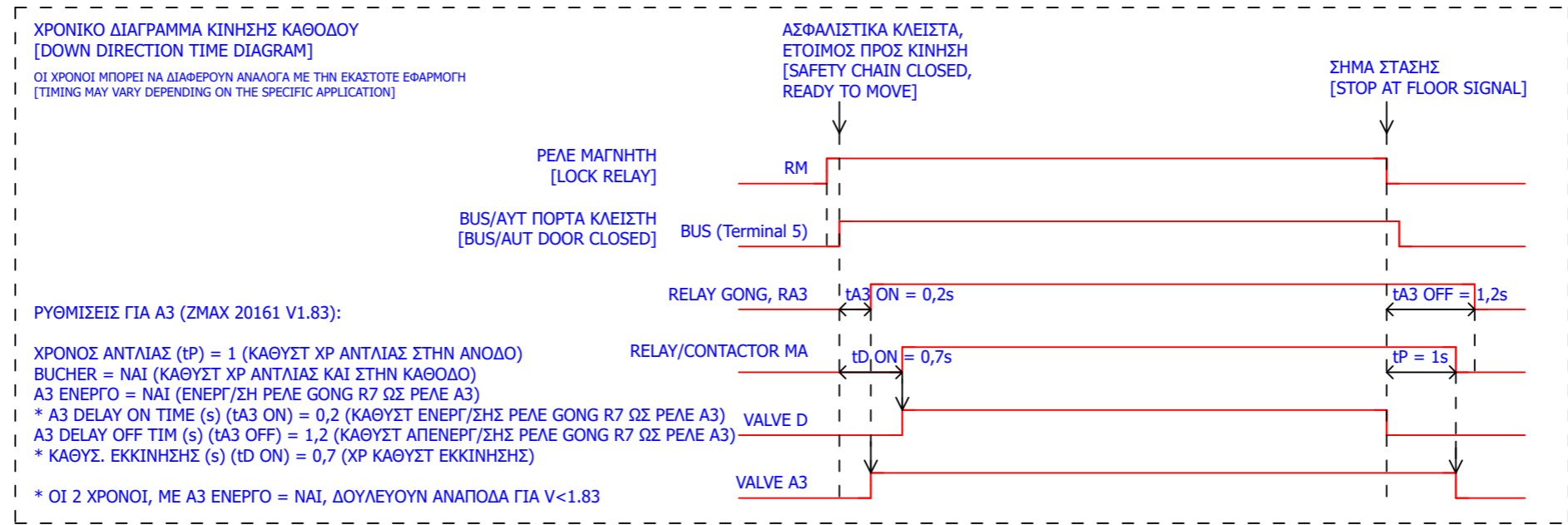
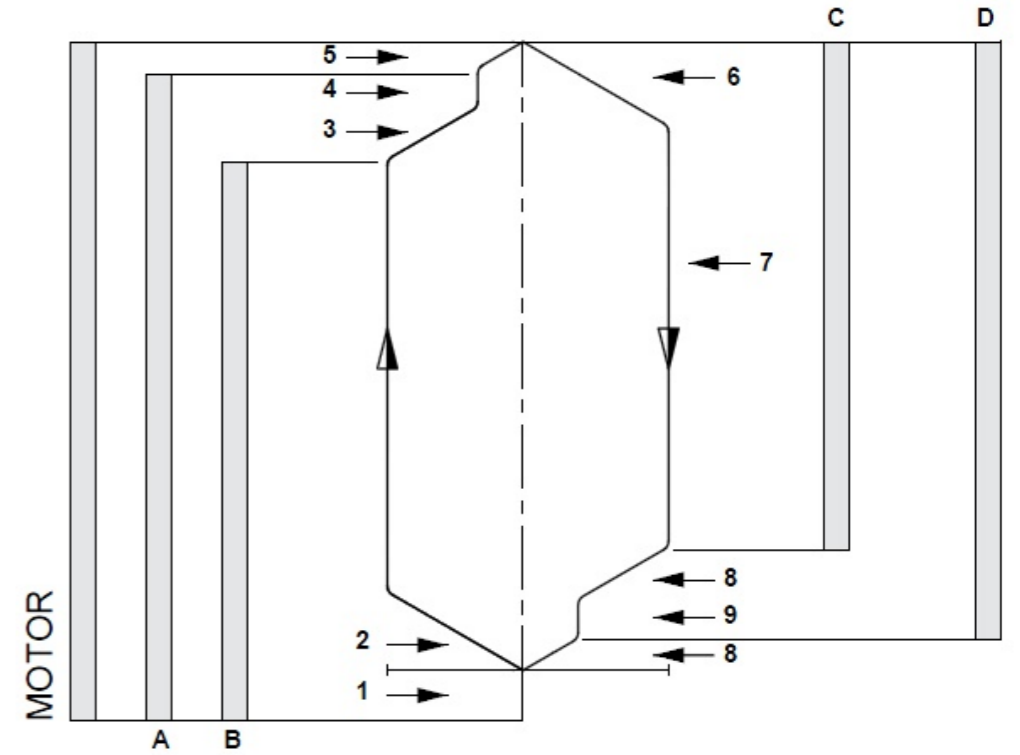
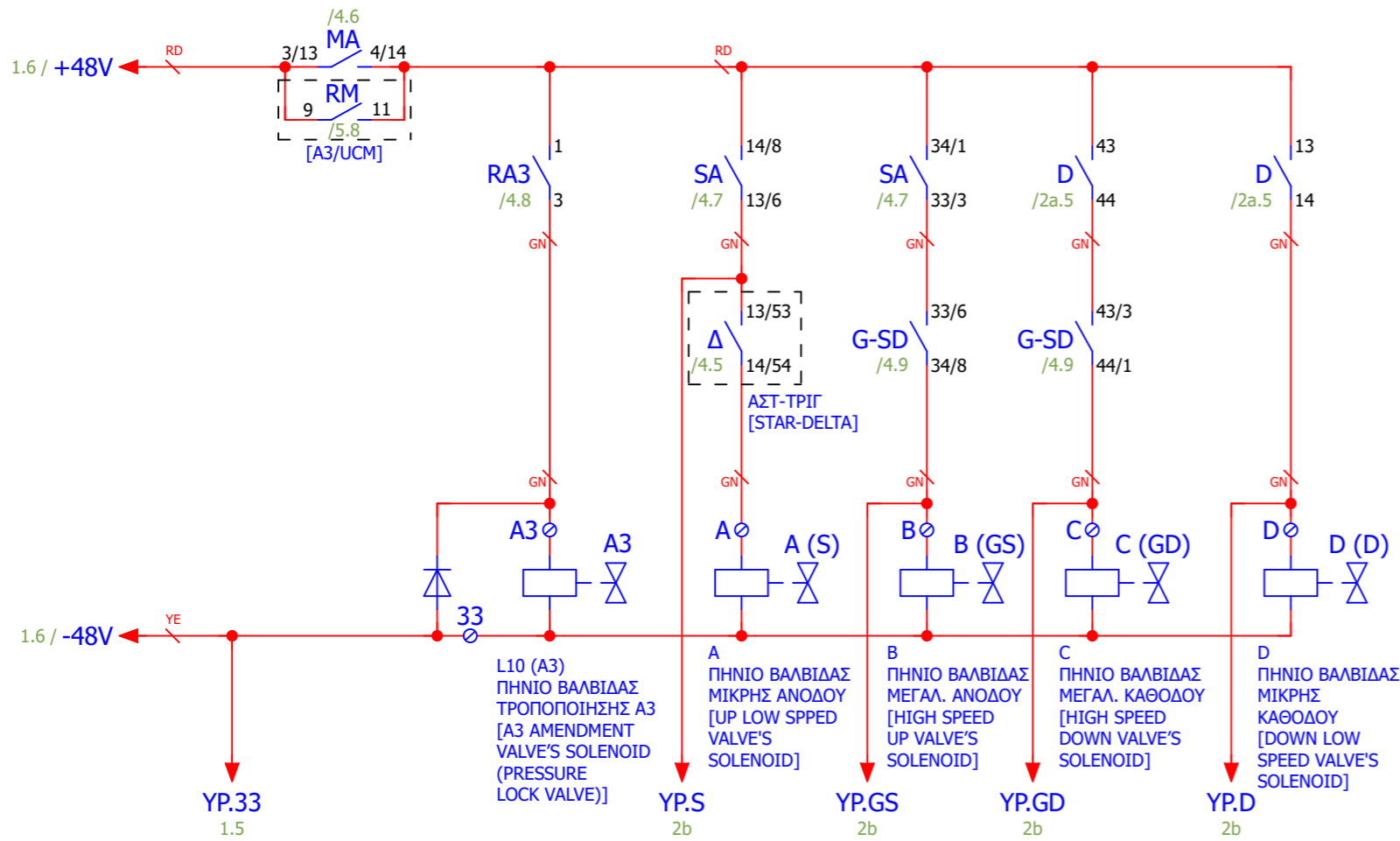

ΜΟΝΑΔΑ ΙΣΧΥΟΣ GMV SOFT STOP 3010/2CH/S + DLV A3 (Παλιό SS)
 [POWER UNIT GMV SOFT STOP 3010/2CH/S + DLV A3 (Old SS)]

TABLE : 04.010.EN VER.: D
 DATE : 03.04.2014

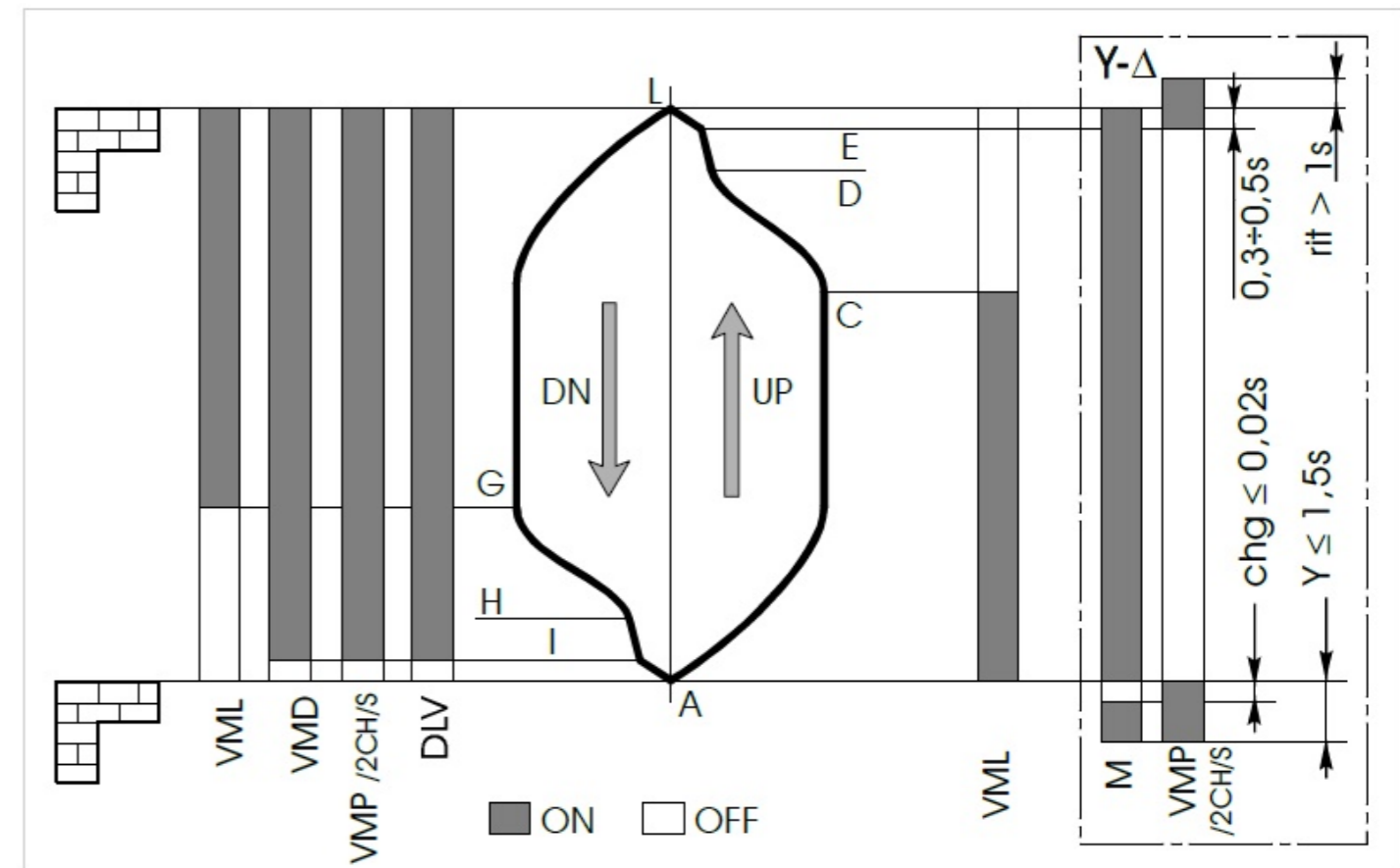
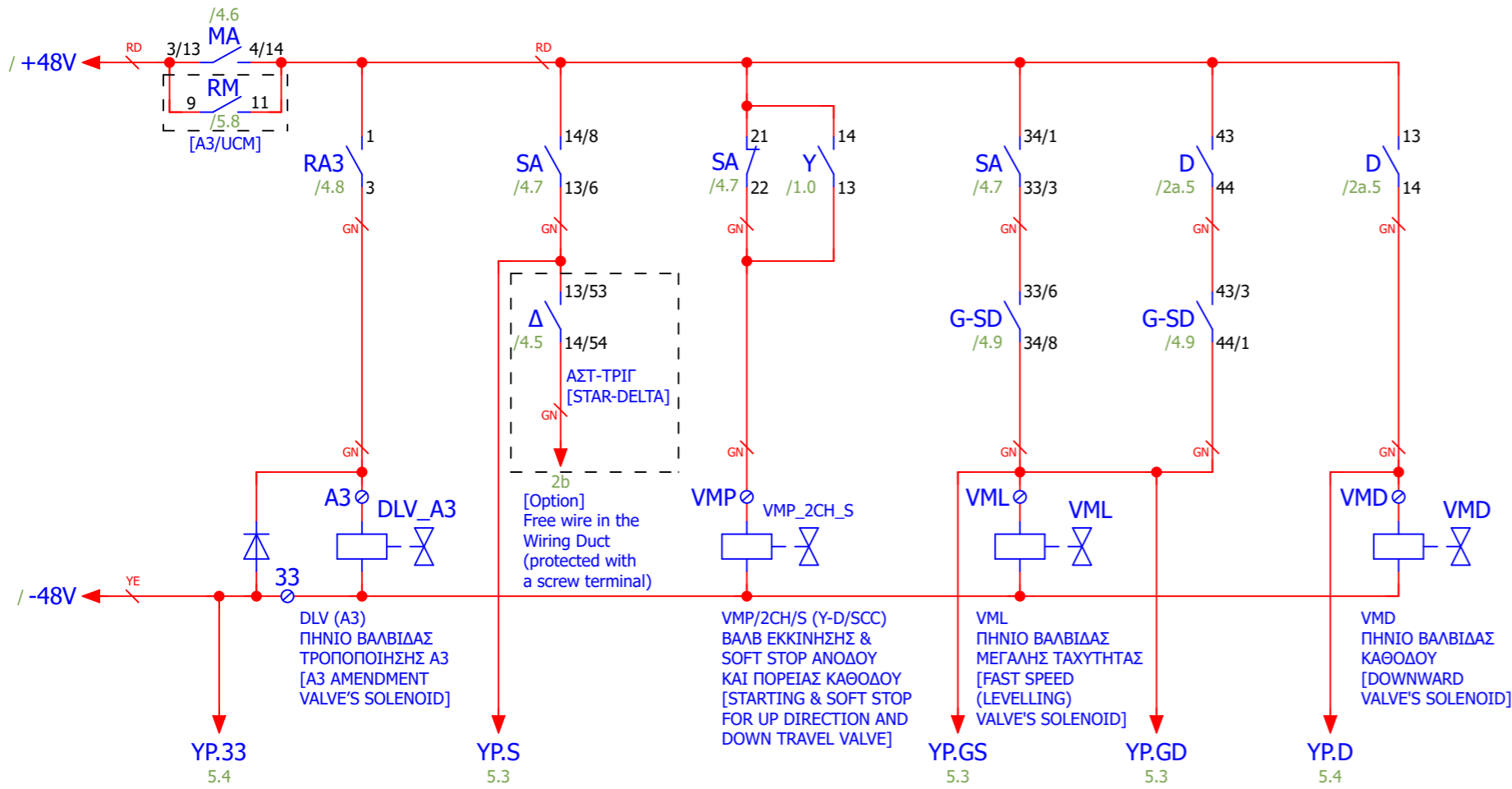

2a

3a

Code: D.ZM.H.DI-SD.A3
 Spec:
 Vers./Rel.: V3.1 3.2 R170323
 Board/Mem: Zero Max V1.83 / V1.85

StamTec - Elevator Control Panels
 Head Office: Ind. Zone of Sindos, OT 43, DA 11, P.C. 57022
 Thessaloniki, GREECE, Tel/Fax: +30 2310-459902, 795880, 795691
 Email: info@stamtec.gr, Website: www.stamtec.gr

StamTec

DWG: Zero Max Panel - Hydraulic Direct & Star-Delta Start (V3.1 & V3.2)

= H
 + V3.1_3.2
 Page: 2b
 Tot. Nr. Pages: 10

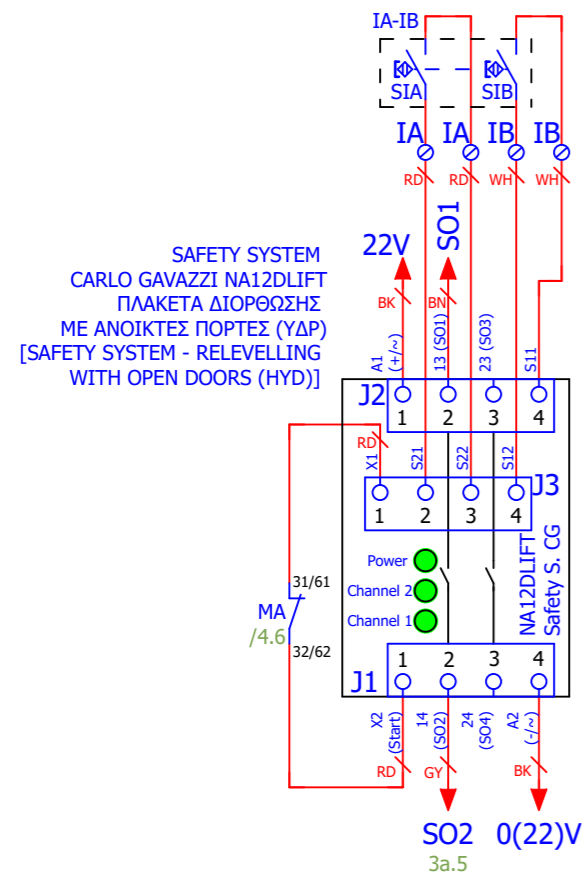

Code: D.ZM.H.DI-SD.A3
Spec:
Vers./Rel.: V3.1 3.2 R170323
Board/Mem: Zero Max V1.83 / V1.85

StamTec - Elevator Control Panels
Head Office: Ind. Zone of Sindos, OT 43, DA 11, P.C. 57022
Thessaloniki, GREECE, Tel/Fax: +30 2310-459902,795880,795691
Email: info@stamtec.gr, Website: www.stamtec.gr



DWG:Zero Max Panel - Hydraulic Direct & Star-Delta Start (V3.1 & V3.2)

= H
+ V3.1_3.2
Page: 3b
Tot. Nr. Pages: 10

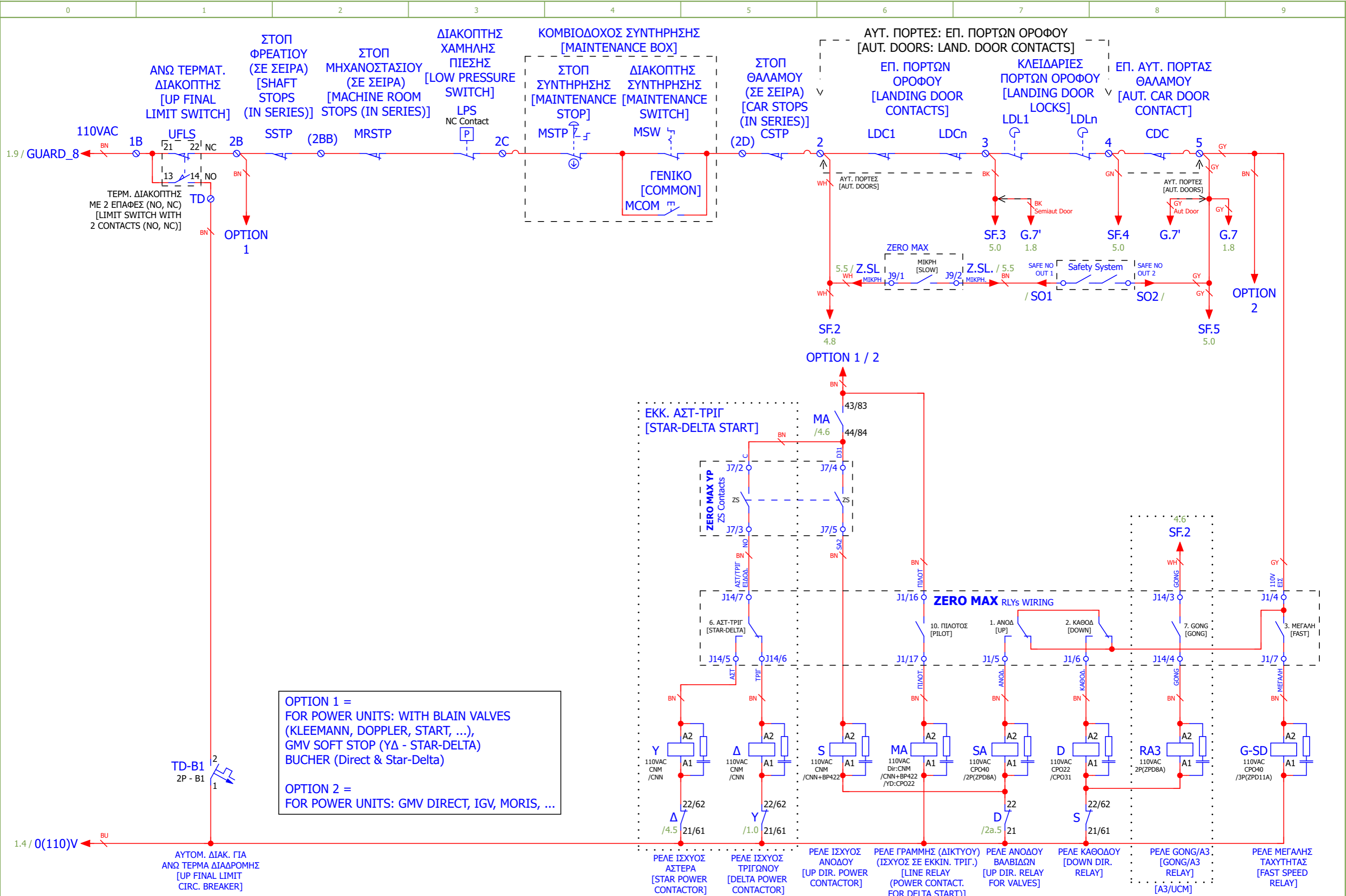

OPTION 1 =
 FOR POWER UNITS: WITH BLAIN VALVES
 (KLEEMANN, DOPPLER, START, ...),
 GMV SOFT STOP (ΥΔ - STAR-DELTA)
 BUCHER (Direct & Star-Delta)

OPTION 2 =
 FOR POWER UNITS: GMV DIRECT, IGV, MORIS, ...

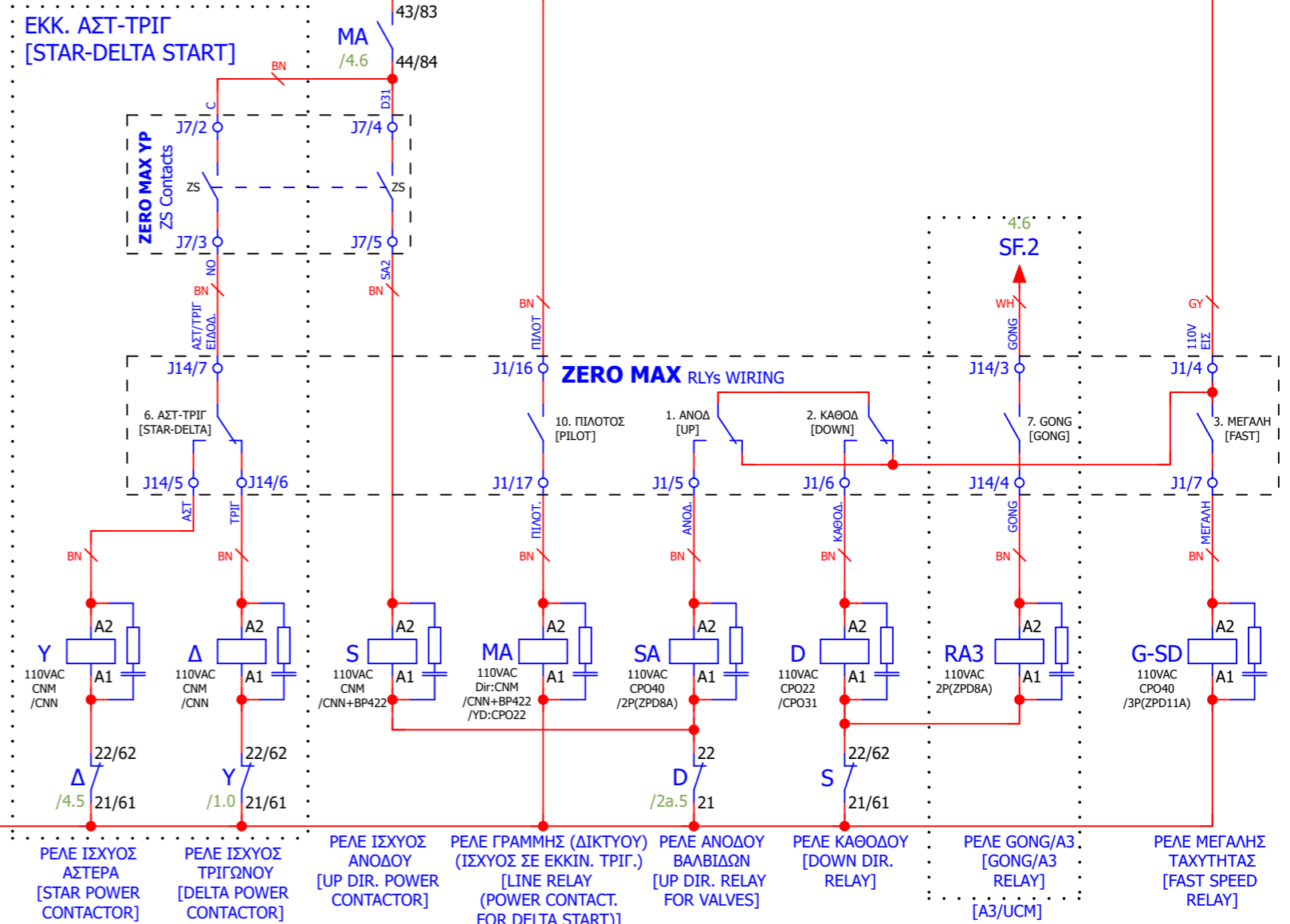

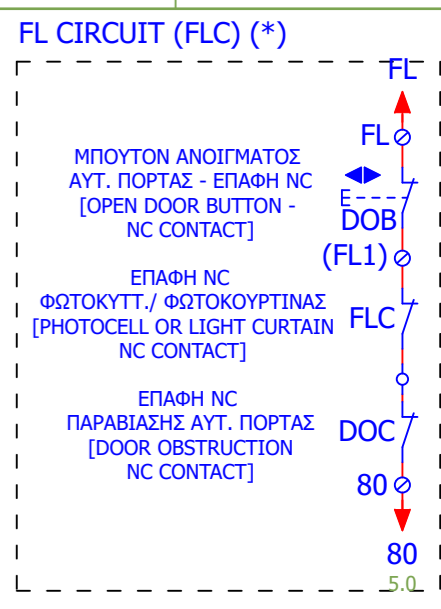
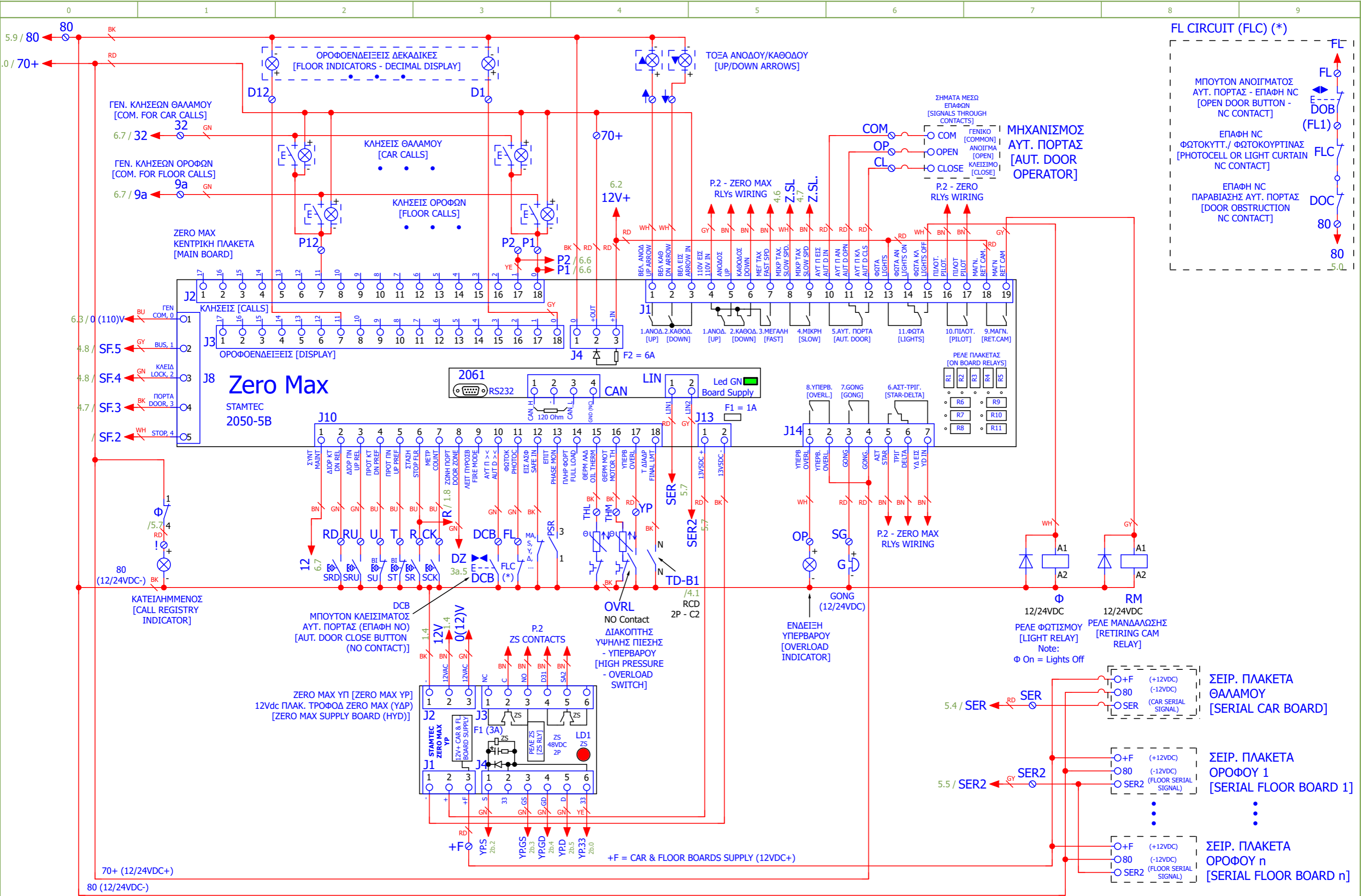

ΤΡΟΦΟΔ ΠΛΑΚΕΤΑΣ ΚΑΙ ΚΥΚΛΩΜΑ ΣΥΝΤΗΡΗΣΗΣ (ΘΑΛΑΜΟΥ ΚΑΙ ΠΙΝΑΚΑ)
[BOARD SUPPLY AND REVISION CIRCUIT (CAR AND PANEL)]

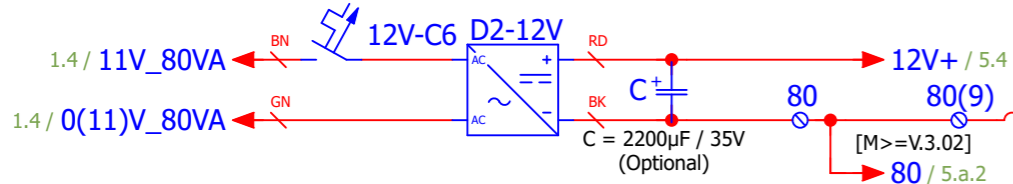

ΚΟΜΒΙΟΔΟΧΟΣ ΣΥΝΤΗΡΗΣΗΣ
[MAINTENANCE BOX]

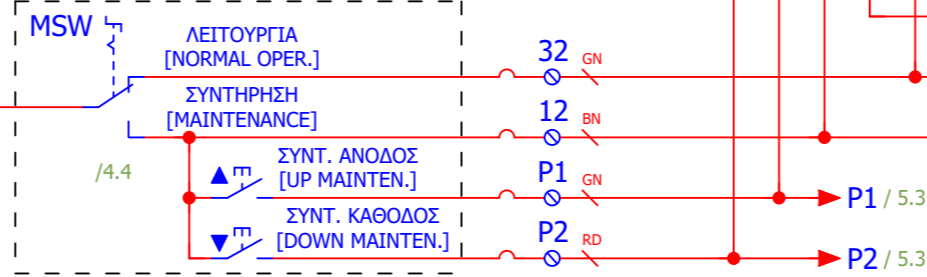

S.D.3-B
ΣΥΝΤΗΡΗΣΗ ΠΙΝΑΚΑ
[PANELS' REVISION]

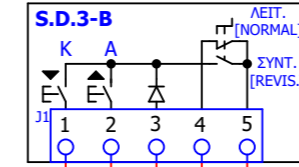

ΓΕΝ. ΚΛΗΣΕΩΝ ΟΡΟΦΩΝ
[COM. FOR FLOOR CALLS]

ΛΕΙΤΟΥΡΓΙΑ
[NORMAL OPER.]

ΣΥΝΤΗΡΗΣΗ
[MAINTENANCE]

ΤΡΟΦΟΔΟΣΙΑ ΑΥΤ ΠΟΡΤΑΣ 230VAC
[AUT CAR DOOR SUPPLY 230VAC]

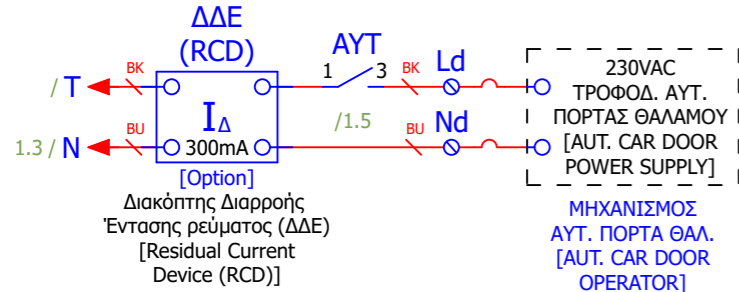

ΤΡΟΦΟΔΟΣΙΑ ΑΥΤ ΠΟΡΤΑΣ 110VAC
[AUT CAR DOOR SUPPLY 110VAC]

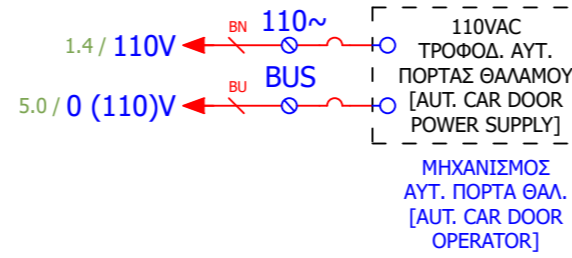

ΦΩΤΑ 42VAC [LIGHTS 42VAC]

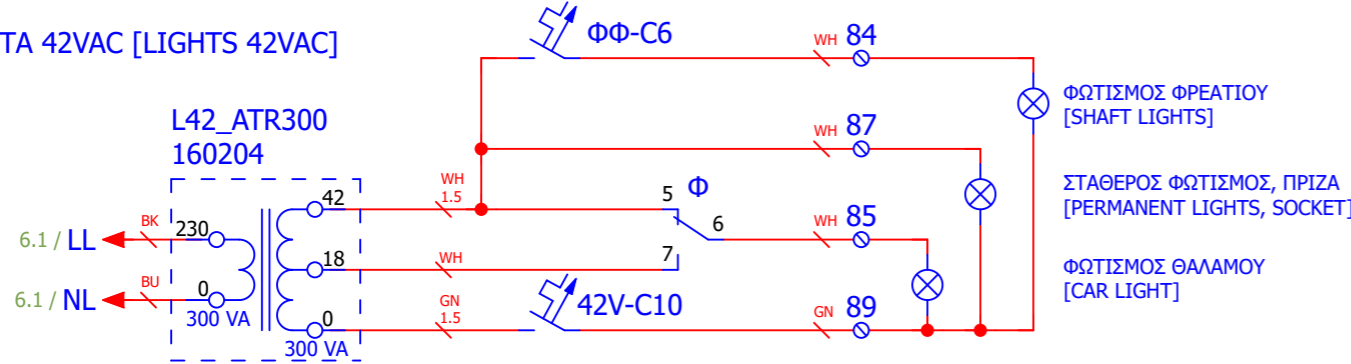

ΦΩΤΑ 230VAC [LIGHTS 230VAC]

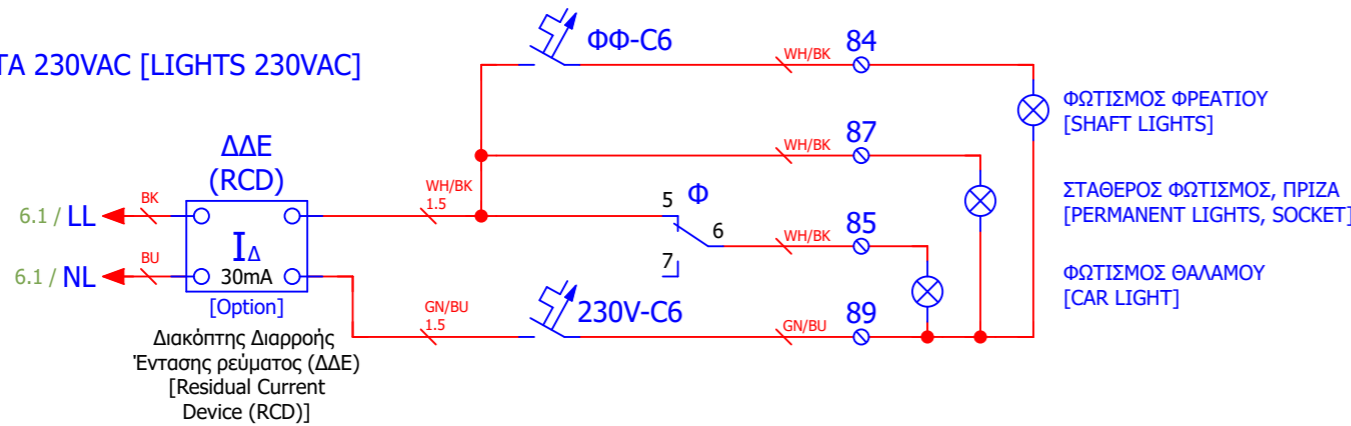

ΠΑΡΑΤΗΡΗΣΗ:
ΟΤΑΝ ΥΠΑΡΧΟΥΝ ΔΙΠΛΑ ΦΩΤΑ 42VAC ΚΑΙ 230VAC
ΟΙ ΚΛΕΜΜΕΣ ΓΙΑ ΤΑ ΦΩΤΑ 230VAC ΓΙΝΟΝΤΑΙ
N89, L85, L87, L84

[NOTE:
IN CASE OF DOUBLE LIGHTS 42VAC AND 230VAC
TERMINALS FOR LIGHTS 230VAC BECOME
N89, L85, L87, L84]